

**1.25Gb/s 20Km 2CH Compact BIDI SFP Transceiver (KWS420D-43)
Hot Pluggable, Dual LC, +3.3V,1490nm DFB-LD, Single-mode, DDM**



- transceiver package
- ✧ Single +3.3V Power Supply
- ✧ Monitoring Interface Compliant with SFF-8472
- ✧ Operating temperature range:
Commercial: 0°C to 70°C
- ✧ RoHS compliant and Lead Free

Features:

- ✧ Support 1.25Gb/s data links
- ✧ Hot-Pluggable
- ✧ LC connector
- ✧ Up to 20Km on 9/125µm SMF
- ✧ 1490nm DFB lasertransmitter
- ✧ 2×Bi-directional transceivers in 1 SFP

Applications:

- ✧ Gigabit Ethernet(1000BASE-BX)
- ✧ Fiber Channel
- ✧ Point to Point FTTH Application
- ✧ Other optical transmission systems

Description:

The CSFP transceivers are high performance, cost effective modules supporting 1.25Gb/s and 20Km transmission distance with SMF. Standard AC coupled CML for high speed signal and LVTTTL control and monitor signals. This module is designed for Single-Mode single fiber, operates at the normal wavelength of TX1490nm/RX1310nm, 2channel. All modules satisfy class I laser safety requirements. The transceivers are compatible with the Compact Small Form-Factor Pluggable(CSFP) Multi-Source Agreement (MSA) option 2, and SFF-8472. For further information, please refer to CSFP MSA.

● **Absolute Maximum Ratings**

Parameter	Symbol	Min.	Typical	Max.	Unit
Storage Temperature	T _s	-40		+85	°C
Supply Voltage	V _{CC}	-0.5		4	V
Relative Humidity	RH	0		85	%

● **Recommended Operating Environment:**

Parameter	Symbol	Min.	Typical	Max.	Unit
Caseoperating Temperature	T _c	0		+70	°C
Supply Voltage	V _{CC}	3.135	3.30	3.465	V
Supply Current	I _{cc}		300	450	mA
Inrush Current	I _{surge}			I _{cc} +30	mA
Maximum Power	P _{max}			1.5	W

● **Electrical Characteristics(T_{OP} = 0 to 70 °C, V_{CC} = 3.135 to 3.465 Volts)**

Parameter	Symbol	Min.	Typical	Max.	Unit	Note
Transmitter Section:						

1.25Gb/s 20Km 2CH Compact BIDI SFP Transceiver (KWS420D-43)
Hot Pluggable, Dual LC, +3.3V,1490nm DFB-LD, Single-mode, DDM

Input differential impedance	R_{in}	90	100	110		
Single ended data input swing	$V_{in PP}$	200		1200	mVp-p	
Transmit Disable Voltage	V_D	$V_{cc} - 1.3$		V_{cc}	V	2
Transmit Enable Voltage	V_{EN}	V_{ee}		$V_{ee} + 0.8$	V	
Transmit Disable Assert Time	$T_{dessert}$			10	us	
Receiver Section:						
Single ended data output swing	$V_{out,pp}$	300		1000	mv	3
LOS Fault	$V_{losfault}$	$V_{cc} - 0.5$		V_{CC_host}	V	5
LOS Normal	$V_{los norm}$	V_{ee}		$V_{ee} + 0.5$	V	5
Power Supply Rejection	PSR	100			mVpp	6

Note:

1. AC coupled.
2. Or open circuit.
3. Into 100 ohm differential termination.
4. 20 – 80 %
5. LOS is LVTTTL. Logic 0 indicates normal operation; logic 1 indicates no signal detected.
6. All transceiver specifications are compliant with a power supply sinusoidal modulation of 20 Hz to 1.5MHz up to specified value applied through the power supply filtering network shown on page 23 of the Small Form-factor Pluggable (SFP) Transceiver Multi-Source Agreement (MSA), September 14, 2000.

● **Optical Characteristics(TOP = 0 to 70°C, VCC = 3.135 to 3.465 Volts)**

Parameter	Symbol	Min.	Typical	Max.	Unit	Note
Transmitter Section:						
Center Wavelength	λ_{cT}	1470	1490	1510	nm	
Spectral Width	σ			1	nm	
Side Mode Suppression Ratio	SMSR	30			dB	
Optical Output Power	P_{out}	-9		-3	dBm	1
Extinction Ratio	ER	8.2			dB	
Optical Rise/Fall Time	t_r / t_f			260	ps	2
Relative Intensity Noise	RIN			-120	dB/Hz	
Output Eye Mask	Compliant with Eye Mask Defined in IEEE 802.3 standard					
Receiver Section:						
Optical Input Wavelength	λ_{cR}	1290	1310	1330	nm	
Receiver Overload	P_{ol}	0			dBm	4
RX Sensitivity	S_{en}			-23	dBm	4
RX_LOS Assert	LOS_A	-35			dBm	
RX_LOS De-assert	LOS_D			-24	dBm	
RX_LOS Hysteresis	LOS_H	0.5			dB	
General Specifications:						
Data Rate	BR		1.25		Gb/s	
Bit Error Rate	BER		10^{-12}			
Max. Supported Link Length on 9/125 μ m SMF@1.25Gb/s	L_{MAX}		20		km	
Total System Budget	LB	14			dB	

Note

**1.25Gb/s 20Km 2CH Compact BIDI SFP Transceiver (KWS420D-43)
Hot Pluggable, Dual LC, +3.3V,1490nm DFB-LD, Single-mode, DDM**

1. The optical power is launched into SMF.
2. 20-80%.
3. Jitter measurements taken using Agilent OMNIBERT 718 in accordance with GR-253.
4. Measured with PRBS 2²³-1 at 10⁻¹² BER

● **Pin Assignment:**

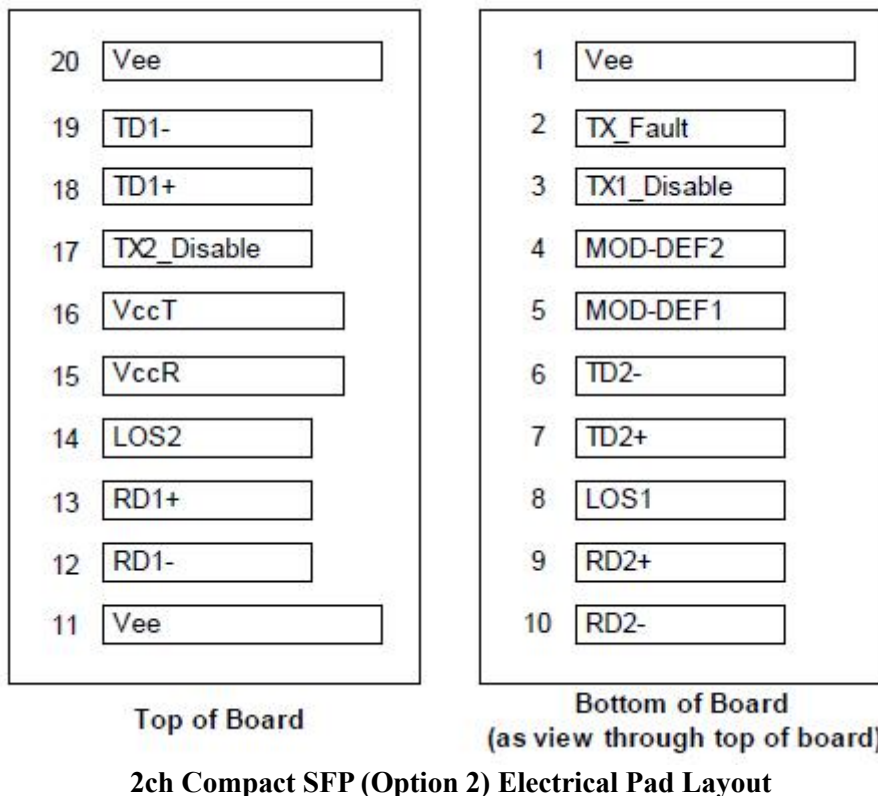

● **Pin Function Definitions**

Pin No	Name	Function	Notes
1	Vee	Ground	1
2	TX Fault	Transmitter Fault Indication	5
3	TX1 Disable	Transmitter disable control of Channel 1, high signal disables optical output of Channel 1	2
4	MOD-DEF2	I2C data (SDA)	3
5	MOD-DEF1	I2C clock (SCL)	3
6	TD2-	Inverted transmitter data input of Channel 2 (internally AC coupled)	6
7	TD2+	Non-inverted transmitter data input of Channel 2 (internally AC coupled)	6
8	LOS1	Open collector/drain output, high signal indicates loss of signal in RX Channel 1	5
9	RD2+	Non-inverted receiver data output of Channel 2 (internally AC coupled)	6
10	RD2-	Inverted receiver data output of Channel 2 (internally AC coupled)	6
11	Vee	Ground	1
12	RD1-	Non-inverted receiver data output of Channel 1 (internally AC coupled)	6
13	RD1+	Inverted receiver data output of Channel 1 (internally AC coupled)	6
14	LOS2	Loss of Signal for channel 2	5

**1.25Gb/s 20Km 2CH Compact BIDI SFP Transceiver (KWS420D-43)
Hot Pluggable, Dual LC, +3.3V,1490nm DFB-LD, Single-mode, DDM**

15	VccR	Receiver Power	1
16	VccT	Transmitter Power	1
17	TX2 Disable	Transmitter disable control of Channel 2, high signal disables optical output of Channel 2	6
18	TD1+	Non-inverted transmitter data input of Channel 1 (internally AC coupled)	6
19	TD1-	Inverted transmitter data input of Channel 1 (internally AC coupled)	6
20	Vee	Ground	1

Notes:

1. Circuit ground is internally isolated from chassis ground.
2. Laser output disabled on TDIS >2.0V or open, enabled on TDIS <0.8V.
3. Should be pulled up with 4.7k - 10 kΩ on host board to a voltage between 2.0V and 3.6V. MOD_DEF(0) pulls line low to indicate module is plugged in.
4. Rate select is not used
5. LOS is open collector output. Should be pulled up with 4.7k – 10 kΩ on host board to a voltage between 2.0V and 3.6V. Logic 0 indicates normal operation; logic 1 indicates loss of signal.
6. AC Coupled

● SFP Module EEPROM Information and Management

The SFP modules implement the 2-wire serial communication protocol as defined in the SFP-8472. The serial ID information of the SFP modules and Digital Diagnostic Monitor parameters can be accessed through the I²C interface at address A0h and A2h.

The memory is mapped in Table 1.

Detailed ID information(A0h) is listed in Table 2.

And the DDM specification at address A2h.

For more details of the memory map and byte definitions, please refer to the SFF-8472, “Digital Diagnostic Monitoring Interface for Optical Transceivers”. The DDM parameters have been internally calibrated.

Table 1. Digital Diagnostic Memory Map (Specific Data Field Descriptions)

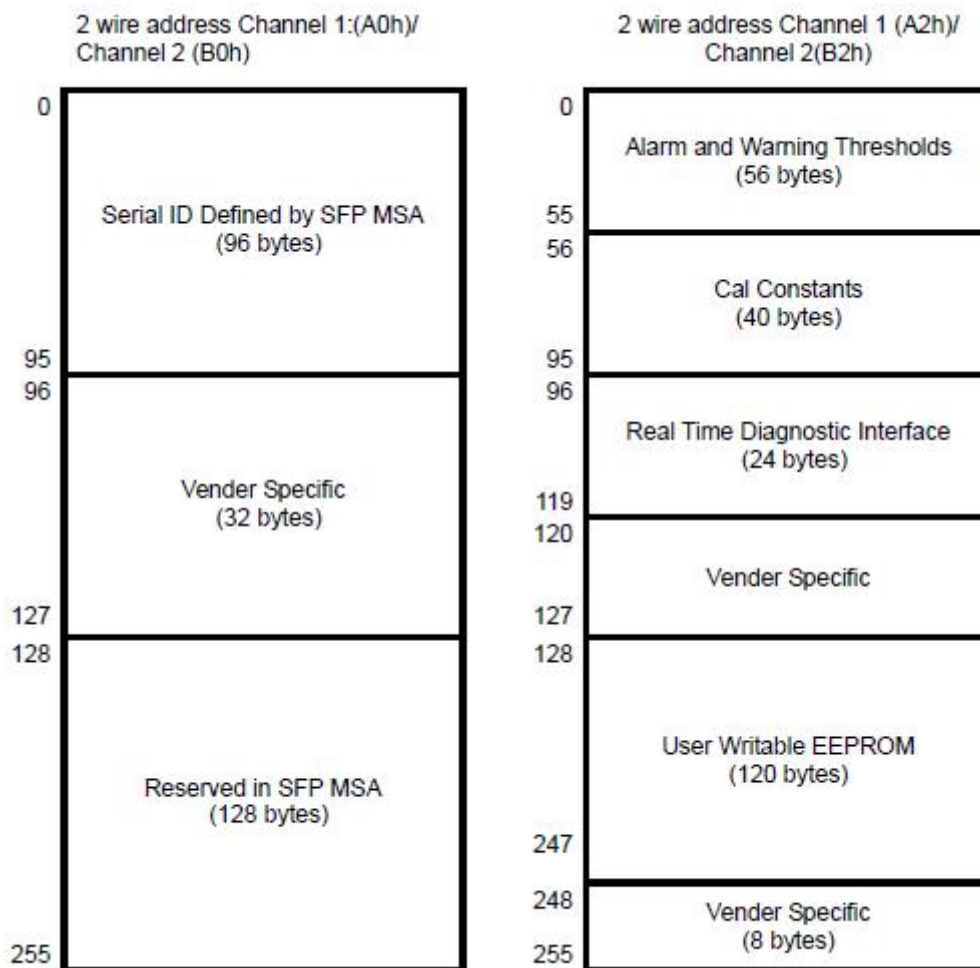

Table 2 -EEPROM Serial ID Memory Contents (A0h)

Data Address	Length (Byte)	Name of Length	Description and Contents
Base ID Fields			
0	1	Identifier	Type of Serial transceiver (03h=SFP)
1	1	Reserved	Extended identifier of type serial transceiver (04h)
2	1	Connector	Code of optical connector type (07=LC)
3-10	8	Transceiver	
11	1	Encoding	NRZ(03h)
12	1	BR, Nominal	Nominal baud rate, unit of 100Mbps
13-14	2	Reserved	(0000h)
15	1	Length(9um)	Link length supported for 9/125um fiber, units of 100m
16	1	Length(50um)	Link length supported for 50/125um fiber, units of 10m
17	1	Length(62.5um)	Link length supported for 62.5/125um fiber, units of 10m
18	1	Length(Copper)	Link length supported for copper, units of meters

**1.25Gb/s 20Km 2CH Compact BIDI SFP Transceiver (KWS420D-43)
Hot Pluggable, Dual LC, +3.3V,1490nm DFB-LD, Single-mode, DDM**

19	1	Reserved	
20-35	16	Vendor Name	SFP vendor name: KEWEI
36	1	Reserved	
37-39	3	Vendor OUI	SFP transceiver vendor OUI ID
40-55	16	Vendor PN	Part Number: "KWS420D-43" (ASCII)
56-59	4	Vendor rev	Revision level for part number
60-62	3	Reserved	
63	1	CCID	Least significant byte of sum of data in address 0-62
Extended ID Fields			
64-65	2	Option	Indicates which optical SFP signals are implemented (001Ah = LOS, TX_FAULT, TX_DISABLE all supported)
66	1	BR, max	Upper bit rate margin, units of %
67	1	BR, min	Lower bit rate margin, units of %
68-83	16	Vendor SN	Serial number (ASCII)
84-91	8	Date code	KEWEI's Manufacturing date code
92-94	3	Reserved	
95	1	CCEX	Check code for the extended ID Fields (addresses 64 to 94)
Vendor Specific ID Fields			
96-127	32	Readable	KEWEI specific date, read only
128-255	128	Reserved	Reserved for SFF-8079

Table 3-Diagnostics Memory Contents (A2h B2h)

Data Address	Length (Byte)	Name of Length	Description and Contents
Diagnostic and control/status fields			
0-39	40	A/W Thresholds	Diagnostic Flag Alarm and Warning Thresholds
40-55	16	Unallocated	
56-91	16	Ext Cal Constants	Diagnostic calibration constants for optional External Calibration
92-94	3	Unallocated	
95	1	CC_DMI	Check code for Base Diagnostic Fields (addresses 0 to 94)
96-105	10	Diagnostics	Diagnostic Monitor Data (internally or externally calibrated)
106-109	4	Unallocated	
110	1	Status/Control	Optional Status and Control Bits
111	1	Reserved	Reserved for SFF-8079
112-113	2	Alarm Flags	Diagnostic Alarm Flag Status Bits
114-115	2	Unallocated	
116-117	2	Warning Flags	Diagnostic Warning Flag Status Bits
118-119	2	Ext Status/Control	Extended module control and status bytes
General use fields			
120-127	8	Vendor Specific	Vendor specific memory addresses
128-247	120	User EEPROM	User writable non-volatile memory
248-255	8	Vendor Control	Vendor specific control addresses

**1.25Gb/s 20Km 2CH Compact BIDI SFP Transceiver (KWS420D-43)
Hot Pluggable, Dual LC, +3.3V,1490nm DFB-LD, Single-mode, DDM**

Table 4–DigitalDiagnosticsMonitor Characteristics

Data Address	Parameter	Accuracy	Unit
96-97	Transceiver Internal Temperature	±3.0	°C
98-99	VCC3 Internal Supply Voltage	±3.0	%
100-101	Laser Bias Current	±10	%
102-103	Tx Output Power	±3.0	dBm
104-105	Rx Input Power	±3.0	dBm

Regulatory Compliance

The KWS420D-43 complies with international Electromagnetic Compatibility (EMC)andinternational safety requirements and standards (see details in Table following).

Electrostatic Discharge (ESD) to the Electrical Pins	MIL-STD-883E Method 3015.7	Class 1(>1000 V)
Electrostatic Discharge (ESD) to the Duplex LC Receptacle	IEC 61000-4-2 GR-1089-CORE	Compatible with standards
Electromagnetic Interference (EMI)	FCC Part 15 Class B EN55022 Class B (CISPR 22B) VCCI Class B	Compatible with standards
Laser Eye Safety	FDA 21CFR 1040.10 and 1040.11 EN60950, EN (IEC) 60825-1,2	Compatible with Class 1 laser product.

1.25Gb/s 20Km 2CH Compact BIDI SFP Transceiver (KWS420D-43)
Hot Pluggable, Dual LC, +3.3V,1490nm DFB-LD, Single-mode, DDM

Recommended Circuit:

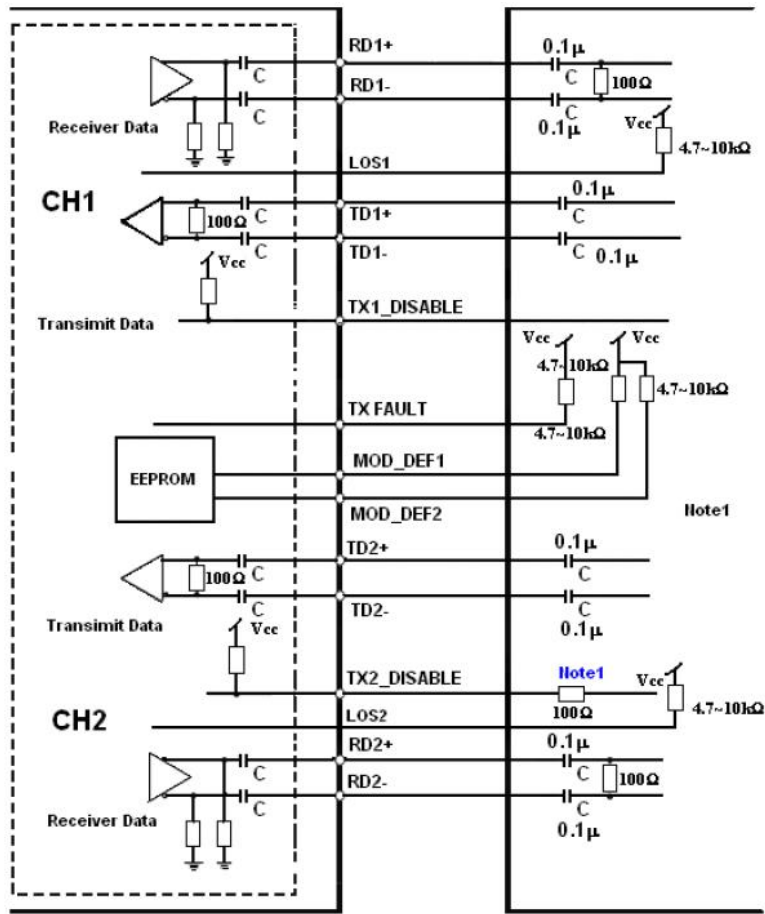

Note1: Recommendation 100_ series resistance on host board

1.25Gb/s 20Km 2CH Compact BIDI SFP Transceiver (KWS420D-43)
Hot Pluggable, Dual LC, +3.3V,1490nm DFB-LD, Single-mode, DDM

Mechanical Dimensions:

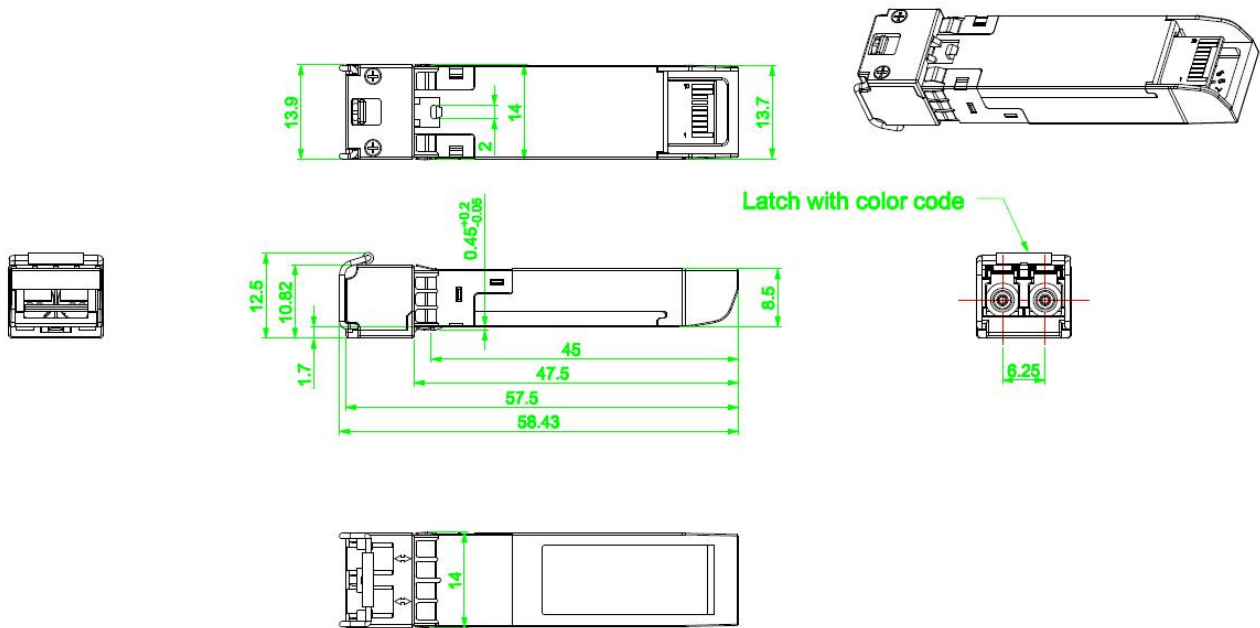

Mechanical Drawing

KEWEI reserves the right to make changes to the products or information contained herein without notice. No liability is assumed as a result of their use or application. No rights under any patent accompany the sale of any such products or information.

Published by Kunshan Kewei Fiber Communications Equipment Co., Ltd.

Copyright © K E W E I

All Rights Reserved