

## Product Features

- QSFP28 MSA compliant
- IEEE 802.3cu compliant
- Non-hermetic package design
- Maximum power consumption 4.0 W
- LC connector
- Up to 2 km transmission on single mode fiber with FEC
- Operating case temperature: 0°C~70°C
- Single 3.3 V power supply
- RoHS compliant

## Applications

- Data Center Network

## Description

KWQE02-SW is a transceiver module designed for 2 km optical communication applications, and it is compliant with IEEE 802.3cu 100GE FR1 standard. This module can convert 4-channel 25.78125 Gbit/s electrical data to 1-channel 106.25 Gbit/s optical signals. Similarly, it can convert 1-channel 106.25 Gbit/s optical signals to 4-channel output electrical data on the receiver side. It has been designed to meet the harshest external operating conditions including temperature, humidity and EMI interference. The module offers very high functionality and feature integration, accessible via a two-wire serial interface.

**Figure 1 Transceiver block diagram**

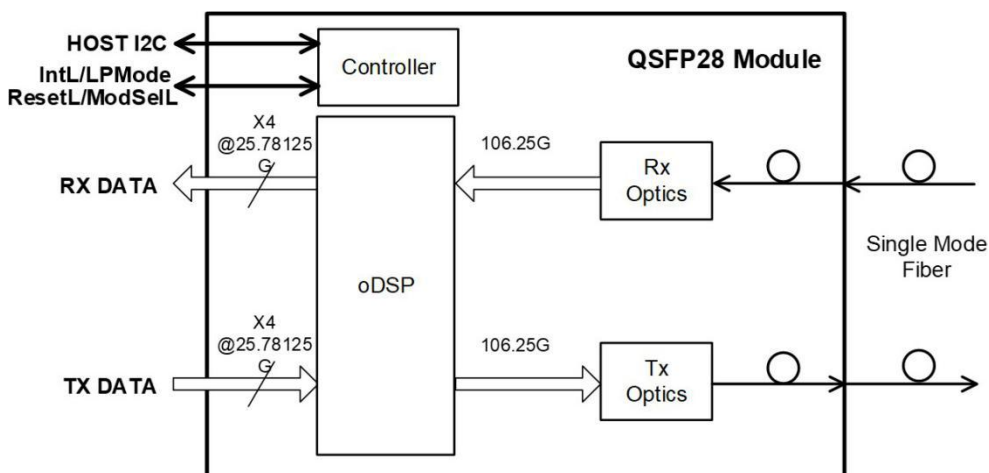

## Pin Descriptions

Figure 2 MSA compliant Connector

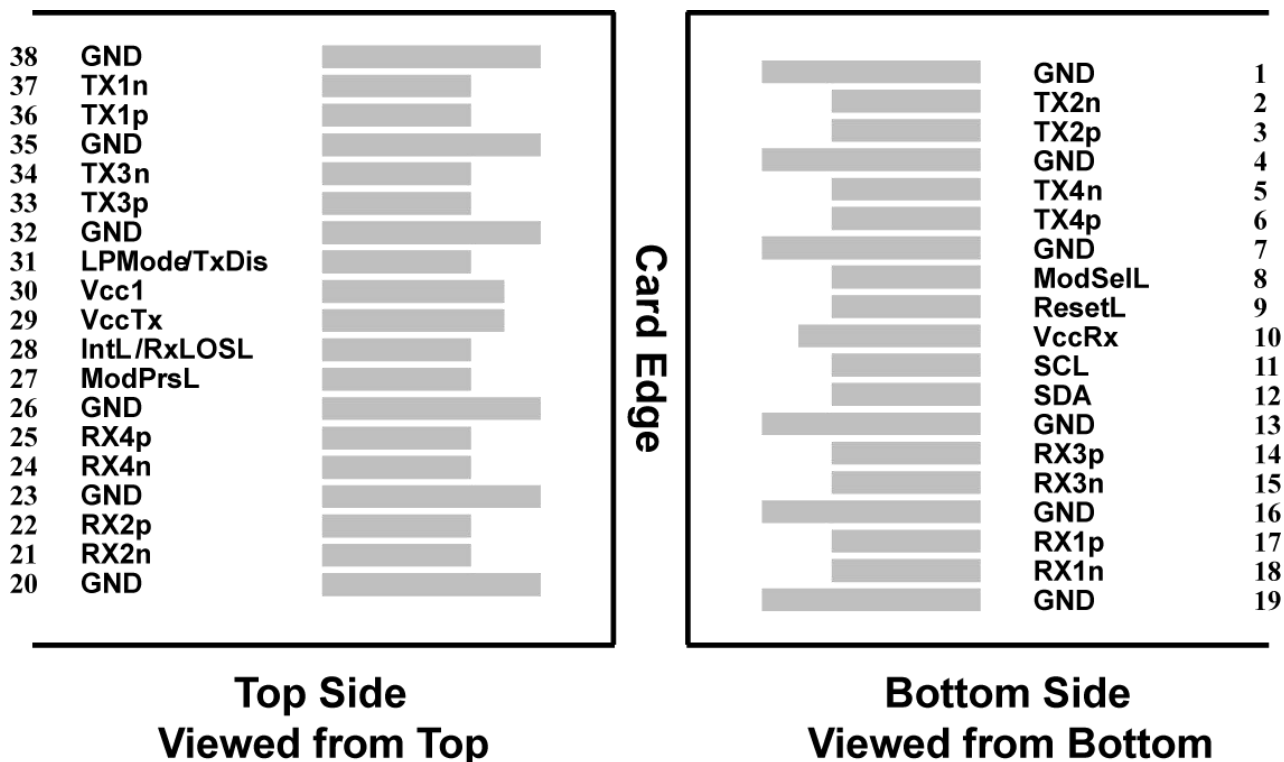

Pin	Symbol	Description	Notes
1	GND	Ground	
2	Tx2n	Transmitter Inverted Data Input	
3	Tx2p	Transmitter Non-Inverted Data Input	
4	GND	Ground	
5	Tx4n	Transmitter Inverted Data Input	
6	Tx4p	Transmitter Non-Inverted Data Input	
7	GND	Ground	
8	ModSelL	Module Select	
9	ResetL	Module Reset	
10	VccRx	+3.3 V Power Supply Receiver	
11	SCL	2-wire serial interface clock	

**100Gb/s QSFP28 FR1 2Km Transceiver (KWQE02-SW)**  
**Hot Pluggable, Duplex LC ,+3.3V,1310nm EML&PIN, Single mode**

12	SDA	2-wire serial interface data	
13	GND	Ground	
14	Rx3p	Receiver Non-Inverted Data Output	
15	Rx3n	Receiver Inverted Data Output	
16	GND	Ground	
17	Rx1p	Receiver Non-Inverted Data Output	
18	Rx1n	Receiver Inverted Data Output	
19	GND	Ground	
20	GND	Ground	
21	Rx2n	Receiver Inverted Data Output	
22	Rx2p	Receiver Non-Inverted Data Output	
23	GND	Ground	
24	Rx4n	Receiver Non-Inverted Data Output	
25	Rx4p	Receiver Inverted Data Output	
26	GND	Ground	
27	ModPrsL	Module Present	
28	IntL/RxLOSL	Interrupt. Optionally configurable as RxLOSL via the management interface (SFF-8636).	
29	VccTx	+3.3 V Power supply transmitter	
30	Vcc1	+3.3 V Power supply	
31	LPMode/TxDis	Low Power Mode. Optionally configurable as TxDis via the management interface (SFF-8636).	
32	GND	Ground	
33	Tx3p	Transmitter Non-Inverted Data Input	
34	Tx3n	Transmitter Inverted Data Input	
35	GND	Ground	
36	Tx1p	Transmitter Non-Inverted Data Input	
37	Tx1n	Transmitter Inverted Data Input	

**100Gb/s QSFP28 FR1 2Km Transceiver (KWQE02-SW)**  
**Hot Pluggable, Duplex LC ,+3.3V,1310nm EML&PIN, Single mode**

38	GND	Ground	
----	-----	--------	--

## Absolute Maximum Ratings

It has to be noted that the operation in excess of any individual absolute maximum ratings might cause permanent damage to this module.

Parameter	Symbol	Min.	Typ.	Max.	Unit	Notes
Maximum Supply Voltage	Vcc	-0.3	3.3	3.6	V	
Storage Temperature	Ts	-40		85	°C	
Relative Humidity	RH	0		85	%	1
Damage Threshold, each lane	THd	5			dBm	

## Operating Environments

Electrical and optical characteristics below are defined under this operating environment, unless otherwise specified.

Parameter	Symbol	Min.	Typ.	Max.	Unit
Supply Voltage	Vcc	3.135	3.3	3.465	V
Case Temperature	T	0		70	°C
Data Rate, each lane			25.78125		Gbit/s
Data Rate Accuracy		-100		100	ppm
Link Distance with G.652		2		2000	m

## Electrical Characteristics

Parameter	Symbol	Min.	Typ.	Max.	Unit	Notes
Power dissipation	P			4.0	W	
Supply Current	Icc			1.212	A	
<b>Transmitter (module output)</b>						

**100Gb/s QSFP28 FR1 2Km Transceiver (KWQE02-SW)  
Hot Pluggable, Duplex LC ,+3.3V,1310nm EML&PIN, Single mode**

Data Rate, each lane		25.78125 ± 100ppm			GBd	
Differential input Voltage pk-pk	Vpp			900	mV	
Common Mode Voltage	Vcm	-350		2850	mV	
Common Mode Noise	RMS			17.5	mV	
Differential Termination Resistance Mismatch				10	%	At 1 MHz
Differential Return Loss	SDD22	See CEI-28-VSR Equation (13-2)			dB	
Common Mode to Differential Conversion	SDC22	See CEI-28-VSR Equation (13-4)			dB	
Common Mode Return Loss	SCC22			-2		From 250 MHz to 30 GHz
Transition Time		9.5			ps	20%~80%
Vertical Eye Closure	VEC			5.5	dB	
Eye Width at 10-15 probability	EW15	0.57			UI	
Eye Height at 10-15 probability	EH15	228			mV	
<b>Receiver (module input)</b>						
Data Rate, each lane		25.78125 ± 100ppm			GBd	
Overload Differential Voltage pk-pk	Vpp	900			mV	
Common Mode Voltage	Vcm	-350		2850	mV	
Differential Termination Resistance Mismatch				10	%	At 1 MHz
Differential Return Loss	SDD11	See CEI-28-VSR Equation (13-2)			dB	
Differential to Common Mode Conversion	SCD11	See CEI-28-VSR Equation (13-3)			dB	
Stressed Input Test		See CEI-28-VSR Section 13.3.11.2.1				

## Optical Characteristics

Parameters	Unit	Min.	Typ.	Max.
<b>Transmitter</b>				
Data Rate	GBd	53.125 ± 100 ppm		
Modulation Format		PAM4		
Line wavelengths	nm	1304.5	1311	1317.5
Average Launch Power	dBm	-3.1		4.0
Optical Modulation Amplitude (OMA) for TDECQ < 1.4 dB for 1.4 dB ≤ TDECQ ≤ 3.4 dB	dBm	-0.1 -1.5+TDECQ		4.2
Extinction Ratio (ER)	dB	3.5		
Side-Mode Suppression Ratio (SMSR)	dB	30		
Transmitter and Dispersion Eye Clouser for PAM4 (TDECQ)	dB			3.4
Transmitter eye closure for PAM4 (TECQ)	dB			3.4
Transmitter transition time	ps			17
Optical Return Loss Tolerance	dB			17.1
Transmitter Reflectance	dB			-26
Average Launch Power of OFF Transmitter	dBm			-15
<b>Receiver</b>				
Data Rate	GBd	53.125 ± 100 ppm		
Modulation Format		PAM4		
Damage Threshold	dBm	5.0		
Line wavelengths	nm	1304.5	1311	1317.5
Average receiver power	dBm	-7.1		4.0

**100Gb/s QSFP28 FR1 2Km Transceiver (KWQE02-SW)  
Hot Pluggable, Duplex LC ,+3.3V,1310nm EML&PIN, Single mode**

Receiver power (OMA)	dBm			4.2
Receiver Sensitivity (OMAuter) (max) for TECQ < 1.4 dB for 1.4 dB ≤ TECQ ≤ 3.4 dB	dBm			-4.5 -5.9+TECQ
Stressed receiver Sensitivity <sup>1</sup> (OMAuter) (max)	dBm			-2.5
LOS Assert	dBm	-15		
LOS Deassert	dBm			-8.6
LOS Hysteresis	dB	0.5		
Receiver reflectance	dB			-26
<b>Conditions of stressed receiver sensitivity<sup>2</sup></b>				
Stressed eye closure for PAM4 (SECQ), lane under test	dB			3.4

**NOTE**

1. Measured with conformance test signal for BER = 2.4x10<sup>-4</sup>.
2. These test conditions are for measuring stressed receiver sensitivity. They are not characteristics of the receiver.

## Digital Diagnostic Monitoring Functions

KWQE02-SW supports the I2C-based Diagnostic Monitoring Interface (DMI) defined in document SFF-8636. The host can access real-time performance of transmitter and receiver optical power, temperature, supply voltage and bias current.

Performance item	Data address		
	Alarm & Warning	Alarm & Warning thresholds	Monitor
Module temperature	Lowpage 6	Page03 (128-135)	Lowpage (22-23)
Module voltage	Lowpage 7	Page03 (144-151)	Lowpage (26-27)
Bias current	Lowpage (11-12)	Page03 (184-191)	Lowpage (42-49)
Transmitter optical power	Lowpage (13-14)	Page03 (192-199)	Lowpage (50-57)
Receiver optical power	Lowpage (9-10)	Page03 (176-183)	Lowpage (34-41)

## Mechanical Specifications

Figure 3 KWQE02-SW Mechanical Dimensions

