

**SFP 2.5Gb/s 80Km Bi-directional Transceiver (KW5680D-45)**  
**Hot Pluggable, LC, +3.3V, 1490nm Tx/1550nm Rx, DFB-LD&APD,Single-mode**



- ✧ Isolation > 30dB, Cross Talk < -45dB
- ✧ Monitoring Interface Compliant with SFF-8472
- ✧ Metal Enclosure, Excellent EMI & ESD Protection
- ✧ Compliant with Specifications for IEEE802.3Z
- ✧ Compliant with Bellcore TA-NWT-000983
- ✧ Eye Safety Designed to Meet Laser Class1, Compliant with IEC60825-1
- ✧ RoHS Compliant

**Features:**

- ✧ Single Mode bi-directional Transmission
- ✧ SFP Multi-source Package with LC Receptacle
- ✧ Up to 2.5Gb/s Data Links
- ✧ Hot-Pluggable Capability
- ✧ Up to 80 km on 9/125µm SMF
- ✧ Single +3.3V Power Supply
- ✧ Built-in WDM

**Applications:**

- ✧ Gigabit Ethernet
- ✧ Fiber Channel
- ✧ WDM Application

**Description:**

KW5680D-45 Bi-Directional transceiver is a high performance, cost effective module ,which is compliant with LC Optics interface with built in WDM for Bi-Directional serial optical data communication applications. This module is designed for Single-Mode single fiber, operates at the normal wavelength of 1490/1550nm.

Standard AC coupled CML for high speed signal and LVTTTL control and monitor signals.

The transmitter section incorporates DFB and driver IC with temperature compensation and automatic power control circuit, which make the transmitter section output power and Extinction ration stabled in operation temperature.

The receiver section incorporates an efficient InGaAs photodiode and transimpedance with AGC for wide dynamic range.

● **Absolute Maximum Ratings**

Parameter	Symbol	Min.	Typical	Max.	Unit
Storage Temperature	T <sub>s</sub>	-40		+85	°C
Supply Voltage	V <sub>ccT, R</sub>	-0.5		4	V
Relative Humidity	RH	0		85	%
Case Operating Temperature	Industrial	-40		85	C
	Extended	-5		85	
	Commercial	0		70	

● **Recommended Operating Environment:**

Parameter		Symbol	Min.	Typical	Max.	Unit
Case operating Temperature	Industrial	T <sub>C</sub>	-40		85	°C
	Extended		-5		85	°C
	Commercial		0		+70	°C
Supply Voltage		V <sub>CCT,R</sub>	3.0		3.6	V

● **Electrical Characteristics(T<sub>OP</sub> = 0 to 70 °C, VCC = 3.0 to 3.60 Volts)**

Parameter	Symbol	Min.	Typical	Max.	Unit	Note
Supply Voltage	V <sub>cc</sub>	3.0	3.30	3.60	V	
Supply Current	I <sub>cc</sub>			300	mA	
Inrush Current	I <sub>surge</sub>			I <sub>cc</sub> +30	mA	
Maximum Power	P <sub>max</sub>			1.0	W	
<b>Transmitter Section:</b>						
Input differential impedance	R <sub>in</sub>	90	100	110		
Single ended data input swing	V <sub>in PP</sub>	200		1200	mVp-p	
Transmit Disable Voltage	V <sub>D</sub>	V <sub>cc</sub> – 1.3		V <sub>cc</sub>	V	2
Transmit Enable Voltage	V <sub>EN</sub>	V <sub>ee</sub>		V <sub>ee</sub> + 0.8	V	
Transmit Disable Assert Time	T <sub>dessert</sub>			10	us	
<b>Receiver Section:</b>						
Single ended data output swing	V <sub>out,pp</sub>	300		1000	mv	3
Data output rise time	t <sub>r</sub>			260	ps	4
Data output fall time	t <sub>f</sub>			260	ps	4
LOS Fault	V <sub>losfault</sub>	V <sub>cc</sub> – 0.5		V <sub>CC_host</sub>	V	5
LOS Normal	V <sub>los norm</sub>	V <sub>ee</sub>		V <sub>ee</sub> +0.5	V	5
Power Supply Rejection	PSR	100			mVpp	6
Deterministic Jitter Contribution	RXΔDJ			51.7	ps	7
Total Jitter Contribution	RXΔTJ			122.4	ps	

Note:

1. AC coupled.
2. Or open circuit.
3. Into 100 ohm differential termination.
4. 20 – 80 %
5. LOS is LVTTTL. Logic 0 indicates normal operation; logic 1 indicates no signal detected.
6. All transceiver specifications are compliant with a power supply sinusoidal modulation of 20 Hz to 1.5MHz up to specified value applied through the power supply filtering network shown on page 23 of the Small Form-factor Pluggable (SFP) Transceiver Multi-Source Agreement (MSA), September 14, 2000.
7. Measured with DJ-free data input signal. In actual application, output DJ will be the sum of input DJ and . DJ.

● **Optical Parameters(T<sub>OP</sub> = 0 to 70 °C, VCC = 3.0 to 3.60 Volts)**

Parameter	Symbol	Min.	Typical	Max.	Unit	Note
-----------	--------	------	---------	------	------	------

**SFP 2.5Gb/s 80Km Bi-directional Transceiver (KW5680D-45)**  
**Hot Pluggable, LC, +3.3V, 1490nm Tx/1550nm Rx, DFB-LD&APD,Single-mode**

<b>Transmitter Section:</b>						
Center Wavelength	$\lambda_c$	1470	1490	1510	nm	1
Spectral Width(-20dB)	$\sigma$			1	nm	
Optical Output Power	$P_{out}$	-2		+3	dBm	2
Optical Rise/Fall Time	$t_r / t_f$			260	ps	3
Extinction Ratio	ER	8.2			dB	
Deterministic Jitter Contribution	TX $\Delta$ DJ			56.5	ps	4
Total Jitter Contribution	TX $\Delta$ TJ			119	ps	
Eye Mask for Optical Output	Compliant with Eye Mask Defined in IEEE 802.3 standard					
Relative Intensity Noise	RIN			-120	dB/Hz	
<b>Receiver Section:</b>						
Optical Input Wavelength		1530	1550	1570	nm	
Optical Input Power	$P_{in}$	-28		-3	dBm	5.6
Receiver Reflectance		12			dB	
Receiver Overload	$P_{ol}$			-9	dBm	5.6
RX Sensitivity	$S_{en}$			-28	dBm	5.6
RX_LOS Assert	LOS <sub>A</sub>	-45			dBm	
RX_LOS Deassert	LOS <sub>D</sub>			-29	dBm	
RX_LOS Hysteresis	LOS <sub>H</sub>	0.5			dB	
<b>General Specifications</b>						
Data Rate	BR	155		2667	Mb/s	
Bit Error Rate	BER			10 <sup>-12</sup>		
Max. Supported Link Length on 9/125 $\mu$ m SMF@1.25G	LMAX			80	km	7
Total System Budget	LB	26			dB	8

**Note**

1. Also specified to meet curves in FC-PI 13.0 Figures 18 and 19, which allow trade-off between wavelength spectral width.
2. Class 1 Laser Safety per FDA/CDRH and EN (IEC) 60825 regulations.
3. Unfiltered, 20-80%. Complies with IEEE 802.3 (Gig. E), FC 1x and 2x eye masks when filtered.
4. Measured with DJ-free data input signal. In actual application, output DJ will be the sum of input DJ and . DJ.
5. Measured with conformance signals defined in FC-PI 13.0 specifications.
6. Measured with PRBS 2<sup>7</sup> -1 at 10<sup>-12</sup> BER
7. Dispersion limited per FC-PI Rev. 13
8. .Attenuation of 0.25 dB/km is used for the link length calculations. Distances are indicative only. Please refer to the Optical Specifications in Table IV to calculate a more accurate link budget based on specific conditions in your application.

● **Digital Diagnostic Monitor Characteristics**

The following digital diagnostic characteristics are defined over the Recommended Operating Environment unless otherwise specified. It is compliant to SFF8472 Rev10.2 with internal calibration mode. For external calibration mode please contact our sales stuff..

Parameter	Symbol	Min.	Max.	Unit
Temperature monitor absolute error	DMI_Temp	-3	3	degC

**SFP 2.5Gb/s 80Km Bi-directional Transceiver (KW5680D-45)**  
**Hot Pluggable, LC, +3.3V, 1490nm Tx/1550nm Rx, DFB-LD&APD,Single-mode**

Laser power monitor absolute error	DMI_TX	-3	3	dB
RX power monitor absolute error	DMI_RX	-3	3	dB
Supply voltage monitor absolute error	DMI_VCC	-0.1	0.1	V
Bias current monitor absolute error	DMI_Ibias	-10%	10%	mA

● **Block Diagram of Transceiver:**

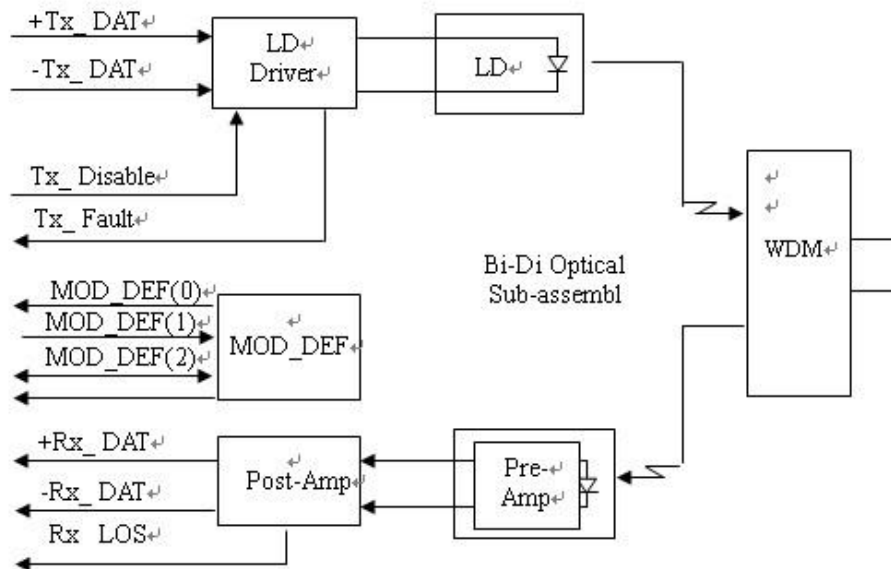

Figure1: Block Diagram

● **Pin Assignment:**

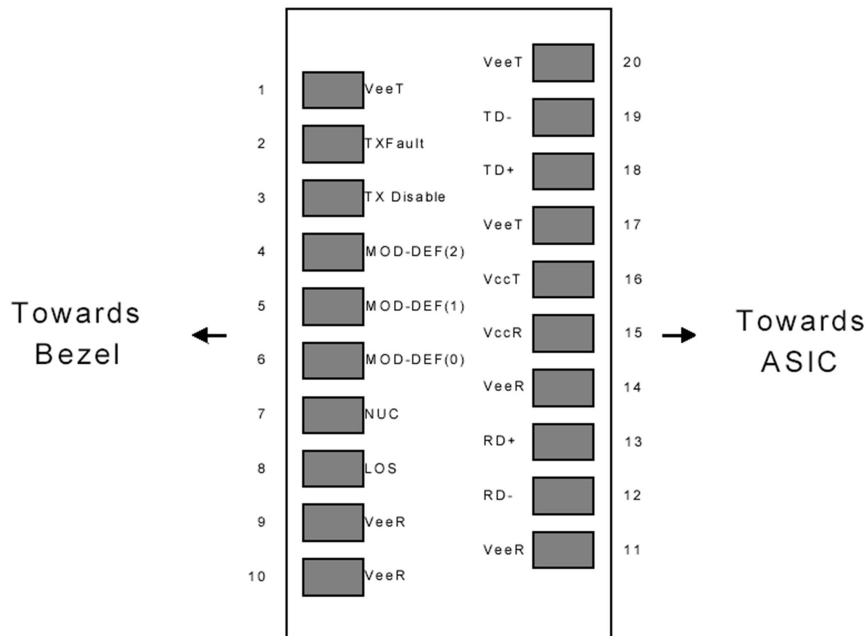
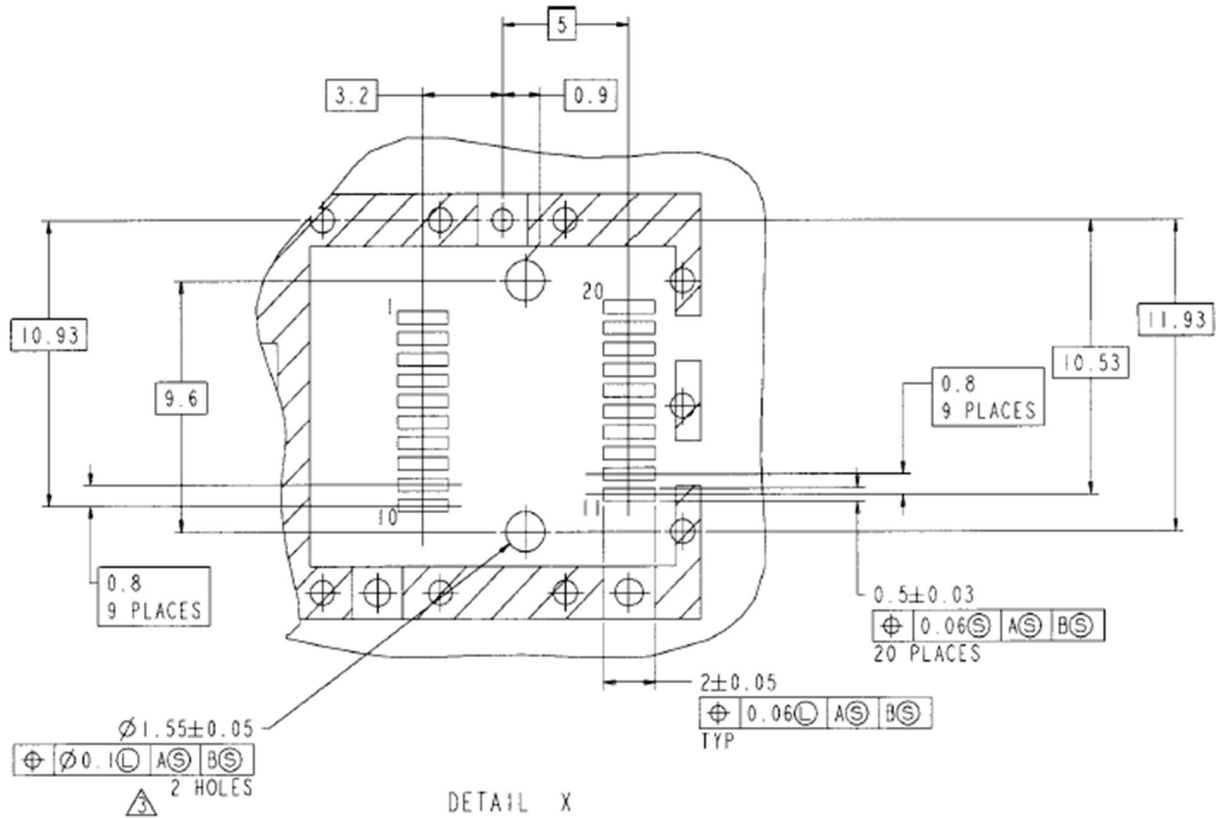
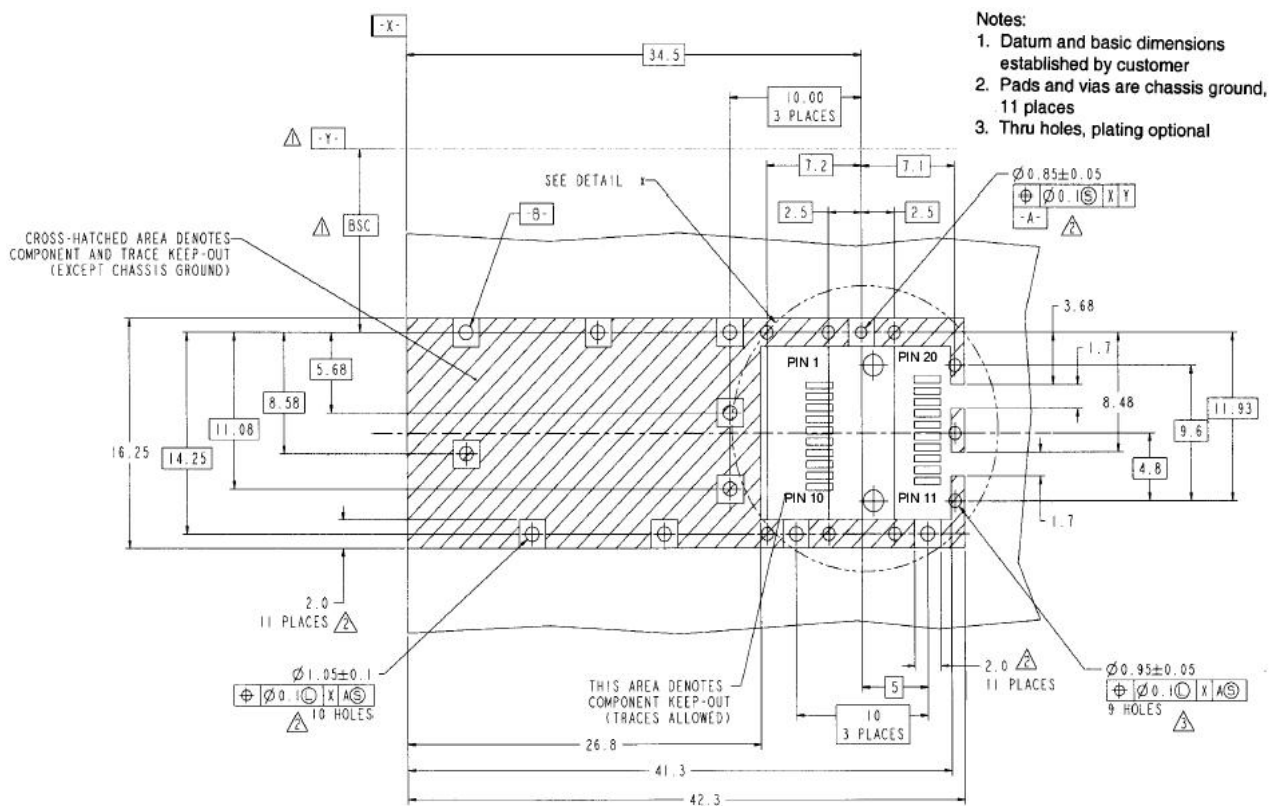

Figure2:Diagram of Host Board Connector Block Pin Numbers and Names

**SFP 2.5Gb/s 80Km Bi-directional Transceiver (KW5680D-45)**  
**Hot Pluggable, LC, +3.3V, 1490nm Tx/1550nm Rx, DFB-LD&APD,Single-mode**



**Figure 3. SFP Host Board Mechanical Layout**



**Figure 4. SFP Host Board Mechanical Layout(Cont)**

● **Pin Description:**

Pin No	Name	Function	Plug Seq	Notes
1	VeeT	Transmitter Ground	1	1
2	TX Fault	Transmitter Fault Indication	3	
3	TX Disable	Transmitter Disable	3	2
4	MOD-DEF2	Module Definition	2	3
5	MOD-DEF1	Module Definition 1	3	3
6	MOD-DEF0	Module Definition 0	3	3
7	Rate Select	Not Connected	3	4
8	LOS	Loss of Signal	3	5
9	VeeR	Receiver Ground	1	1
10	VeeR	Receiver Ground	1	1
11	VeeR	Receiver Ground		1
12	RD-	Inv. Received Data Out	3	6
13	RD+	Received Data Out	3	6
14	VeeR	Receiver Ground	3	1
15	VccR	Receiver Power	2	1
16	VccT	Transmitter Power	2	
17	VeeT	Transmitter Ground	1	
18	TD+	Transmit Data In	3	6
19	TD-	Inv. Transmit In	3	6
20	VeeT	Transmitter Ground	1	

**Notes:**

1. Circuit ground is internally isolated from chassis ground.
2. Laser output disabled on TDIS >2.0V or open, enabled on TDIS <0.8V.
3. Should be pulled up with 4.7k - 10 kohms on host board to a voltage between 2.0V and 3.6V. MOD\_DEF(0) pulls line low to indicate module is plugged in.
4. Rate select is not used
5. LOS is open collector output. Should be pulled up with 4.7k – 10 kohms on host board to a voltage between 2.0V and 3.6V. Logic 0 indicates normal operation; logic 1 indicates loss of signal.
6. AC Coupled

● **Recommended Circuit:**

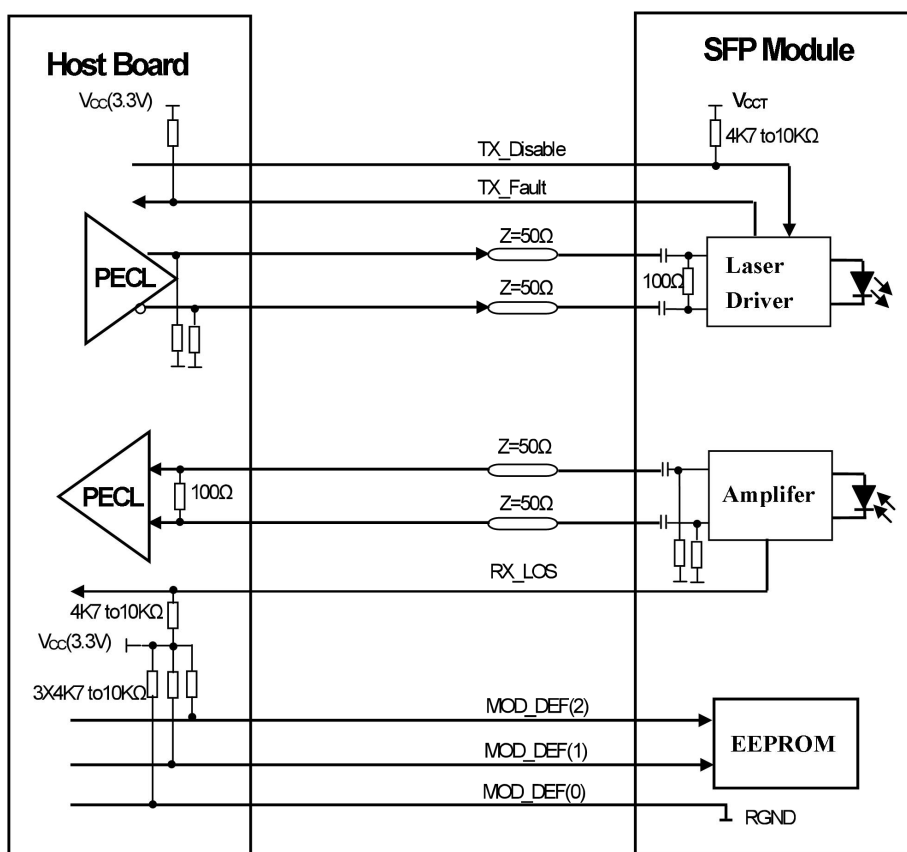

Figure 5. SFP Host Recommended Circuit

● **Serial ID Memory Contents:**

Data Address	Length (Byte)	Name of Length	Description and Contents
Base ID Fields			
0	1	Identifier	Type of Serial transceiver (03h=SFP)
1	1	Reserved	Extended identifier of type serial transceiver (04h)
2	1	Connector	Code of optical connector type (07=LC)
3-10	8	Transceiver	Gigabit Ethernet 1000Base-BX
11	1	Encoding	8B10B (01h)
12	1	BR,Nominal	Nominal baud rate, unit of 100Mbps
13	1	Reserved	(0000h)
14	1	Length(9um,km)	Link length supported for 9/125um fiber, units of km
15	1	Length(9um)	Link length supported for 9/125um fiber, units of 100m
16	1	Length(50um)	Link length supported for 50/125um fiber, units of 10m
17	1	Length(62.5um)	Link length supported for 62.5/125um fiber, units of 10m
18	1	Length(Copper)	Link length supported for copper, units of meters
19	1	Reserved	
20-35	16	Vendor Name	SFP vendor name:
36	1	Reserved	
37-39	3	Vendor OUI	SFP transceiver vendor OUI ID

**SFP 2.5Gb/s 80Km Bi-directional Transceiver (KW5680D-45)**  
**Hot Pluggable, LC, +3.3V, 1490nm Tx/1550nm Rx, DFB-LD&APD,Single-mode**

40-55	16	Vendor PN	Part Number: "KWxxxxx" (ASCII
56-59	4	Vendor rev	)Revision level for part number
60-61	2	Wavelength	Laser wavelength
62	1	Reserved	
63	1	CCID	Least significant byte of sum of data in address 0-62
Extended ID Fields			
64-65	2	Option	Indicates which optical SFP signals are implemented(001Ah = LOS, TX_FAULT, TX_DISABLE all supported)
66	1	BR, max	Upper bit rate margin, units of %
67	1	BR, min	Lower bit rate margin, units of %
68-83	16	Vendor SN	Serial number (ASCII)
84-91	8	Date code	Manufacturing date code
92	1	Diagnostic Type	Diagnostics
93	1	Enhanced Options	Diagnostics
94	1	SFF-8472	Diagnostics
95	1	CCEX	Check code for the extended ID Fields (addresses 64 to 94)
Vendor Specific ID Fields			
96-127	32	Readable	Vendor specific date, read only

● **Diagnostics Memory Contents(A2h):**

Data Address	Length (Byte)	Name of Length	Description and Contents
<b>Diagnostic and control/status fields</b>			
0-39	40	A/W Thresholds	Diagnostic Flag Alarm and Warning Thresholds
40-55	16	Unallocated	
56-91	16	Ext Cal Constants	Diagnostic calibration constants for optional External Calibration
92-94	3	Unallocated	
95	1	CC_DMI	Check code for Base Diagnostic Fields (addresses 0 to 94)
96-105	10	Diagnostics	Diagnostic Monitor Data (internally or externally calibrated)
106-109	4	Unallocated	
110	1	Status/Control	Optional Status and Control Bits
111	1	Reserved	Reserved for SFF-8079
112-113	2	Alarm Flags	Diagnostic Alarm Flag Status Bits
114-115	2	Unallocated	
116-117	2	Warning Flags	Diagnostic Warning Flag Status Bits
118-119	2	Ext Status/Control	Extended module control and status bytes
<b>General use fields</b>			
120-127	8	Vendor Specific	Vendor specific memory addresses
128-247	120	User EEPROM	User writable non-volatile memory
248-255	8	Vendor Control	Vendor specific control addresses



● Mechanical Dimensions:

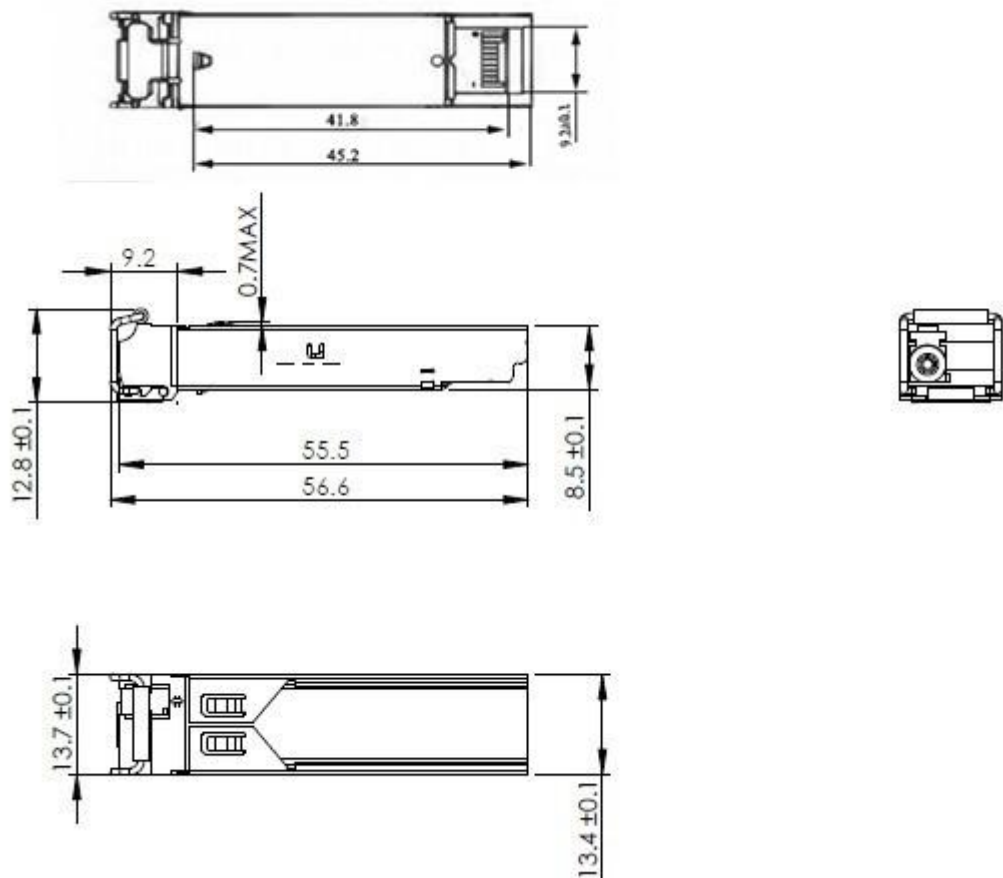

Figure 6. Mechanical Drawing

KEWEI reserves the right to make changes to the products or information contained herein without notice. No liability is assumed as a result of their use or application. No rights under any patent accompany the sale of any such products or information.

Published by Kunshan Kewei Fiber Communications Equipment Co.,Ltd

Copyright © KEWEI

All Rights Reserved