

**25Gb/s 10km SFP28 BIDI Transceiver(KW5010D-XXXX,KW5010DI-XXXX)
Hot Pluggable, Single LC, +3.3V, 1271&1331nm DFB,PIN Receiver, Single mode**



Features:

- ✧ UP to 25.78Gb/s bi-directional data links
- ✧ Hot-Pluggable SFP28 footprint
- ✧ Single LC for Bi-directional Transmission
- ✧ 1271nm DFB laser transmitter for OP5010D-2733, OP5010DI-2733
- ✧ 1331nm DFB laser transmitter for OP5010D-3327, OP5010DI-3327
- ✧ Up to 10km on 9/125um SMF

- ✧ 2-wire interface for management specifications compliant with SFF 8472 digital diagnostic monitoring interface for optical transceivers
- ✧ Power Supply :+3.3V
- ✧ Operating case temperature Range:
Commercial: 0~ 70°C
Industrial:-40~ 85°C
- ✧ RoHS compliant

Applications:

- ✧ 25GE LR
- ✧ eCPRI&CPRI

Part Number Ordering Information

KW5010D-2733	SFP28 LR 10km BIDI optical transceiver with full real-time digital diagnostic monitoring ,1271nm Transmitter&1331nm Receiver,0~70°C, 25GE
KW5010D-3327	SFP28 LR 10km BIDI optical transceiver with full real-time digital diagnostic monitoring , 1331nm Transmitter&1271nm Receiver, 0~70°C, 25GE
KW5010DI-2733	SFP28 LR 10km BIDI optical transceiver with full real-time digital diagnostic monitoring ,1271nm Transmitter&1331nm Receiver,-40~85°C, 25GE
KW5010DI-3327	SFP28 LR 10km BIDI optical transceiver with full real-time digital diagnostic monitoring , 1331nm Transmitter&1271nm Receiver, -40~85°C, 25GE

Description:

KEWEI's K W 5010D-XXXX/KW5010DI-XXXX SFP28 transceivers are designed for use in Ethernet links up to 25.78 Gb/s data rate and up to 10 km link length. They are compliant SFF-8472 , and compatible with SFF-8432 and applicable portions of SFF-8431. The product is RoHS compliant and lead-free per Directive 2011/96/EU.

● Pin Function Definitions

PIN #	Name	Function	Notes
1	VeeT	Module transmitter ground	1
2	Fault	Module transmitter Fault	2
3	Disable	Transmitter Disable; Turns off transmitter laser output	3
4	SDL	2 wire serial interface data input/output (SDA)	4

**25Gb/s 10km SFP28 BIDI Transceiver(KW5010D-XXXX,KW5010DI-XXXX)
Hot Pluggable, Single LC, +3.3V, 1271&1331nm DFB,PIN Receiver, Single mod**

5	SCL	2 wire serial interface clock input (SCL)	4
6	MOD-ABS	Module Absent, connect to VeeR or VeeT in the module	2
7	RS0	Rate select0: module inputs and are pulled low to VeeT with > 30 kΩ resistors in the module.	
8	LOS	Receiver Loss of Signal Indication	
9	RS1	Rate select1: module inputs and are pulled low to VeeT with > 30 kΩ resistors in the module.	
10	VeeR	Module receiver ground	1
11	VeeR	Module receiver ground	1
12	RD-	Receiver inverted data out put	
13	RD+	Receiver non-inverted data out put	
14	VeeR	Module receiver ground	1
15	VccR	Module receiver 3.3V supply	
16	VccT	Module transmitter 3.3V supply	
17	VeeT	Module transmitter ground	1
18	TD+	Transmitter non-inverted data out put	
19	TD-	Transmitter inverted data out put	
20	VeeT	Module transmitter ground	1

Note:

- 1.The module ground pins shall be isolated from the module case.
- 2.This pin is an open collector/drain output pin and shall be pulled up with 4.7K-10Kohms to Host_Vcc on the host board.
- 3.This pin shall be pulled up with 4.7K-10Kohms to VccT in the module.
- 4.This pin is an open collector/drain output pin and shall be pulled up with 4.7K-10Kohms to Host_Vcc on the host board.

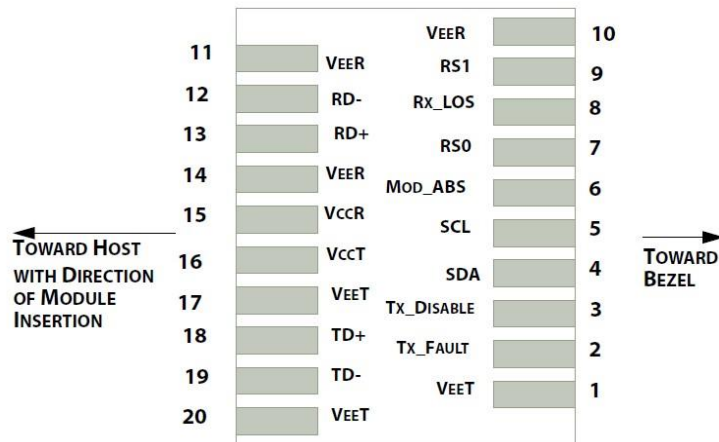

Diagram of Host Board Connector Block Pin Numbers and Names

● **Absolute Maximum Ratings**

Parameter	Symbol	Min.	Typical	Max.	Unit	Note
Storage Temperature	T _S	-40		+85	°C	
Case Operating Temperature	T _A	0		+70	°C	Commercial
Case Operating Temperature	T _A	-40		+85	°C	Industrial
Maximum Supply Voltage	V _{cc}	0		3.6	V	
Relative Humidity(Non-condensing)	RH	0		85	%	

● **Electrical Characteristics**

Parameter	Symbol	Min.	Typical	Max.	Unit	Note
Supply Voltage	V _{cc}	3.14		3.46	V	
Supply Current	I _{cc}			450	mA	Industrial
Power Consumption	P			1.5	W	Industrial
Data Rate	R		25.78		Gb/s	
Fiber Length	L			10	KM	
Transmitter Section:						
Input differential impedance	R _{in}		100		Ω	1
Differential input voltage swing	V _{in,pp}	180		450	mV	2
Transmit Disable Voltage	V _D	2		V _{cc}	V	3
Transmit Enable Voltage	V _{EN}	V _{ee}		V _{ee} +0.8	V	
Receiver Section:						
Single Ended Output Voltage Tolerance	V	-0.3		4	V	
Rx Output Diff Voltage	V _o	180		450	mV	
LOS Fault	V _{LOS fault}	2		V _{ccHOS} _T	V	4
LOS Normal	V _{LOS norm}	V _{ee}		V _{ee} +0.8	V	4

Note:

1. Connected directly to TX data input pins. AC coupling from pins into laser driver IC.
2. Per SFF-8431 Rev 3.0
3. Into 100 ohms differential termination.
4. LOS is an open collector output. Should be pulled up with 4.7k – 10kΩ on the host board. Normal operation is logic 0; loss of signal is logic 1. Maximum pull-up voltage is 5.5V.

● **Optical Characteristics**

Parameter	Symbol	Min.	Typical	Max.	Unit	Note
Transmitter Section:						
Center Wavelength	λ _t	1260	1271	1280	nm	1271 Tx
		1320	1331	1340	nm	1331 Tx
spectral width(-20dB)	Δλ			1	nm	
Average Optical Power	P _{avg}	-5.0		+2.0	dBm	
Laser Off Power	P _{off}			-30	dBm	
Side Mode Suppression Ratio		30				
Extinction Ratio	ER	3.5			dB	
Optical Return Loss Tolerance				-20	dB	
Receiver Section:						
Center Wavelength	λ _r	1260		1370	nm	
Average Receiver Power	S _{en}	-12		-2	dBm	
OMA Receiver Sensitivity	OMA			-12		1
Los Assert	LOS _A	-30		-	dBm	

25Gb/s 10km SFP28 BIDI Transceiver(KW5010D-XXXX,KW5010DI-XXXX)
Hot Pluggable, Single LC, +3.3V, 1271&1331nm DFB,PIN Receiver, Single mode

Los Dessert	LOS _D			-14	dBm	
Los Hysteresis	LOS _H	0.5			dB	
Overload		2			dBm	

Note:

1. Measured with a PRBS 2³¹-1 test pattern, @25.78Gb/s, BER<5E-5.

● **Timing Characteristics**

Parameter	Symbol	Min.	Typical	Max.	Unit
TX_Disable Assert Time	t_off			100	us
TX_Disable Negate Time	t_on			2	ms
Time to Initialize 2-wire interface	t_2w_start_up			300	ms
Time to Initialize	t_start_up			300	ms
Time to Initialize cooled module and time to power up a cooled module to Power level II	t_start_up_cooled			90	s
Time to Power Up to Level II	t_power_level2			300	ms
Time to Power Down from Level II	t_power_down			300	ms
Tx_Fault assert	Tx_Fault_on			1	ms
Tx_Fault assert for cooled module	Tx_Fault_on_cooled			50	ms
TX_FAULT Reset	t_reset	10			us
Rx_LOS assert delay	t_los_on			100	us
Rx_LOS negate delay	t_los_off			100	us

● **Digital Diagnostic Specifications**

Parameter	Symbol	Units	Min	Max	Accuracy	Note
Transceiver Temperature	Temp	°C	-40	+85	±5°C	Industrial
			0	+70	±5 °C	Commercial
Transceiver Supply Voltage	Voltage	V	3.15	3.45	±3%	
Transmitter Bias Current	Bias	mA	0	35	±10%	
Transmitter Output Power	Tx-Power	dBm	-5	+2	±3dB	
Receiver Average Optical Input Power	Rx-Power	dBm	-12	-2	±3dB	

● Recommended Circuit:

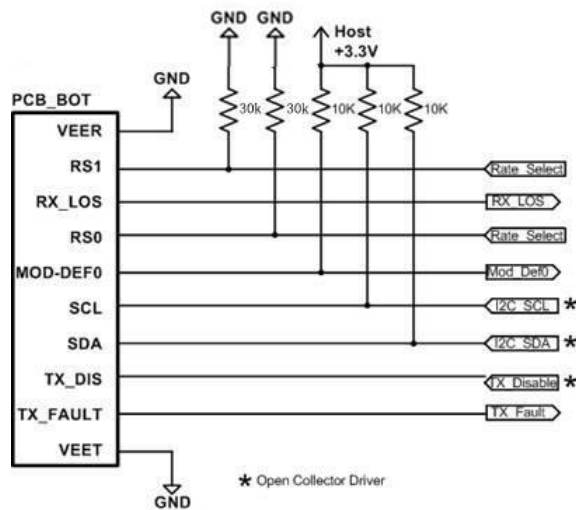
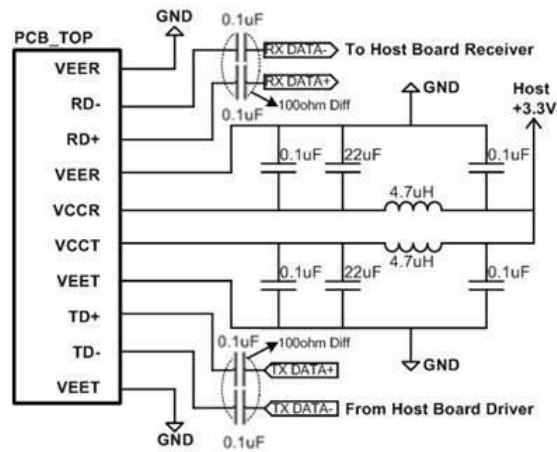

Recommended High-speed Interface Circuit

● Mechanical Dimensions:

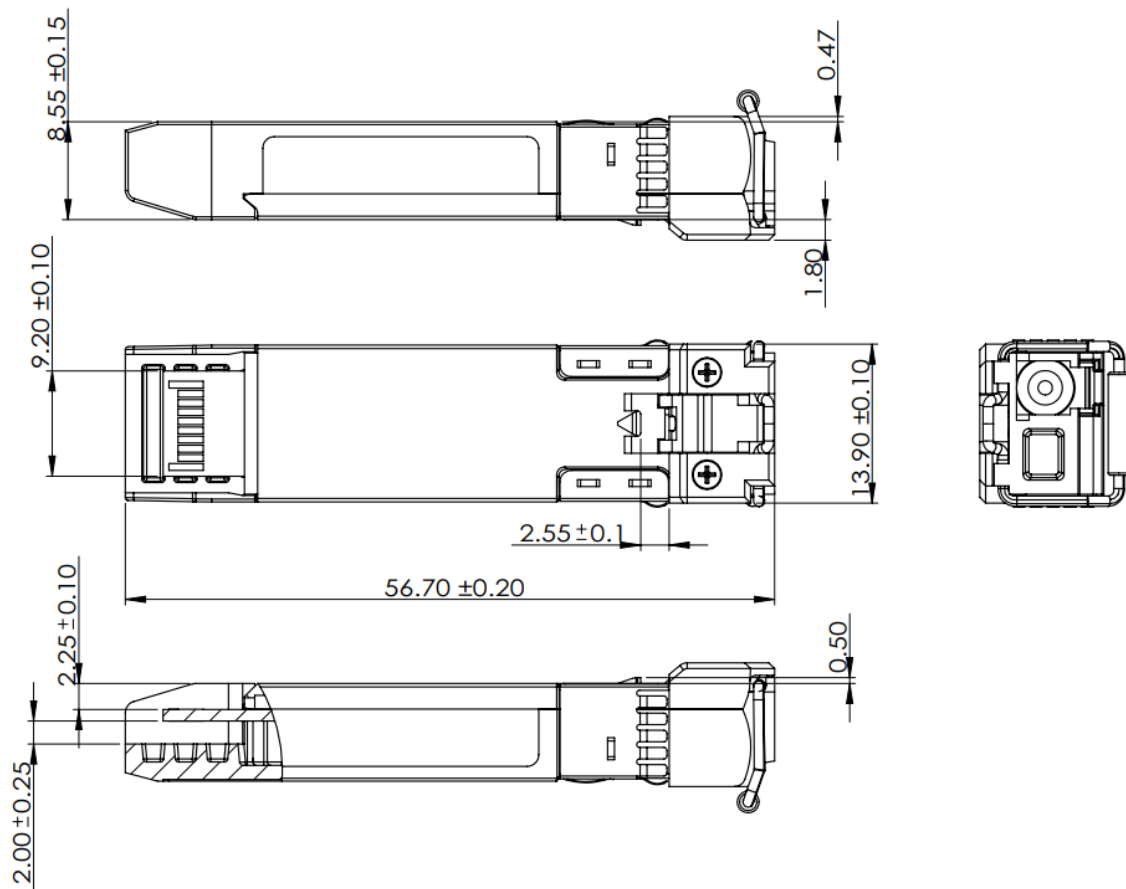

Published by Kunshan Kewei Fiber Communications
Equipment Co., Ltd.
Copyright © KEWEI
All Rights Reserved